



February 7th, 2010

17s Gold Tournament – 8:00am Start

Pool A

1. Lincoln Elite Lasers 17s
2. Omaha Wave 171
3. NE Impact 16 Select Banzai

Pool B

1. Premier 17 Gold
2. High Flyers 171
3. Waverly Jrs 171
4. Nebraska Jrs 161

Pool C

1. Omaha Wave 15 Ice
2. NE Impact 17 Select Affinity
3. Nebraska Jrs 171
4. Crush 171

Court - Union Bank

8:00 AM	XXXXX
9:00 AM	A1 vs A3 (A2)
10:00 AM	A2 vs A3 (A1)
11:00 AM	A1 vs A2 (A3)

Court - Midlands

B1 vs B3 (B2)
B2 vs B4 (B1)
B1 vs B4 (B3)
B2 vs B3 (B4)

Court - All In One

C1 vs C3 (C2)
C2 vs C4 (C1)
C1 vs C4 (C3)
C2 vs C3 (C4)

Tournament Play

Court - Union Bank

12:00 PM	CH1) B2 vs C2 (A1)
1:00 PM	CH3) A1 vs wnr CH#1 (Isr CH1)
2:00 PM	CH5) Isr CH1 vs Isr CH2 (Isr CH3)
3:00 PM	CH7) wnr CH3 vs wnr CH4 (Isr CH5)
4:00 PM	XXXXX

Court - Midlands

CH2) C1 vs A2 (B1)
CH4) B1 vs wnr CH2 (Isr CH2)
CO3) C3 vs wnr CO1 (Isr CH4)
CO6) wnr CO2 vs wnr CO3 (Isr CO3)
* CO5) C3 vs wnr CO4 (Isr CO6)

Court - All In One

CO1) B4 vs A4 (A3/B3)
CO2) A3 vs B3 (Isr CO1)
CO4) Isr CO1 vs Isr CO2 (wnr CO2)
* CH6) Isr CH3 vs Isr CH4 (Isr CO4)
XXXXX

* If A1 or B1 loses their first bracket match, then CH6 will be played. If C3 loses their first bracket match, then CO5 will be played.

CH = Championship Bracket CO = Consolation Bracket

Match Play:

Pool play will be best 2 out of 3 sets to 25 points, starting at 0. Third game 0 – 15, if necessary.

Warm-Ups:

2:4:4 for all matches. Warm-ups will be 2 minutes of shared court time, followed by 4 min of hitting for the serving team and 4 min of hitting for the receiving team. Warm-ups can be shortened to 1-3-3 after each team's first match. The officiating team needs to start warm-ups immediately after the completion of the previous match. Please start the warm-ups before having a match-ending huddle. This will help all of us finish the tournament on schedule. Serving is to be completed during each team's court time. THERE IS NO SHARED SERVING.

Tournament Play:

The top 2 teams from each pool will advance to a championship bracket. The remaining teams will advance to a consolation bracket

If there are more teams tied by match record for advancing positions into the Championship tournament than there are available positions, ties will be broken using the playing scenarios on page 194 in the rulebook.

All tournament matches will be best 2 out of 3 sets to 25 points, starting at 0. Third set 0-15, if necessary.

1. BEST SET (games) RECORD
2. HEAD TO HEAD COMPETITION
3. BEST SET RECORD PERCENTAGE (if applicable)
(number of sets won divided by number of sets played)
4. TOTAL POINT DIFFERENTIAL
5. A COIN TOSS, IF NECESSARY

T-SHIRTS WILL BE AWARDED TO FIRST PLACE TEAM.

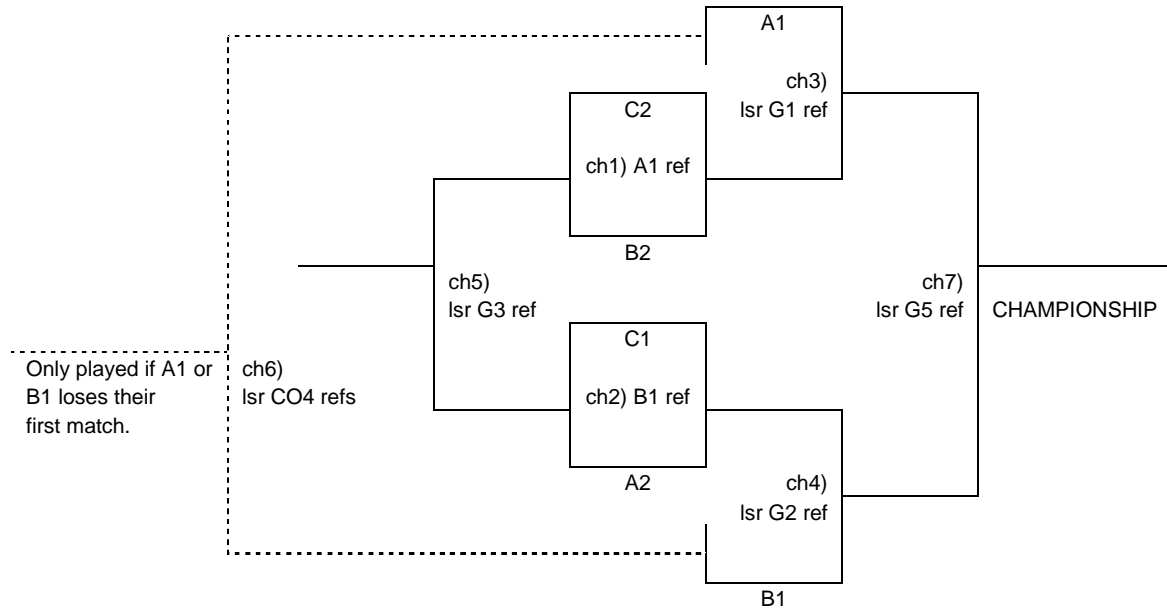

Note: If A1 and B1 both win their first match, the ch6 match is not played. The co5 match can be moved into that slot on the 3rd court with the lsr of co4 reffing at the 3:00 time slot.

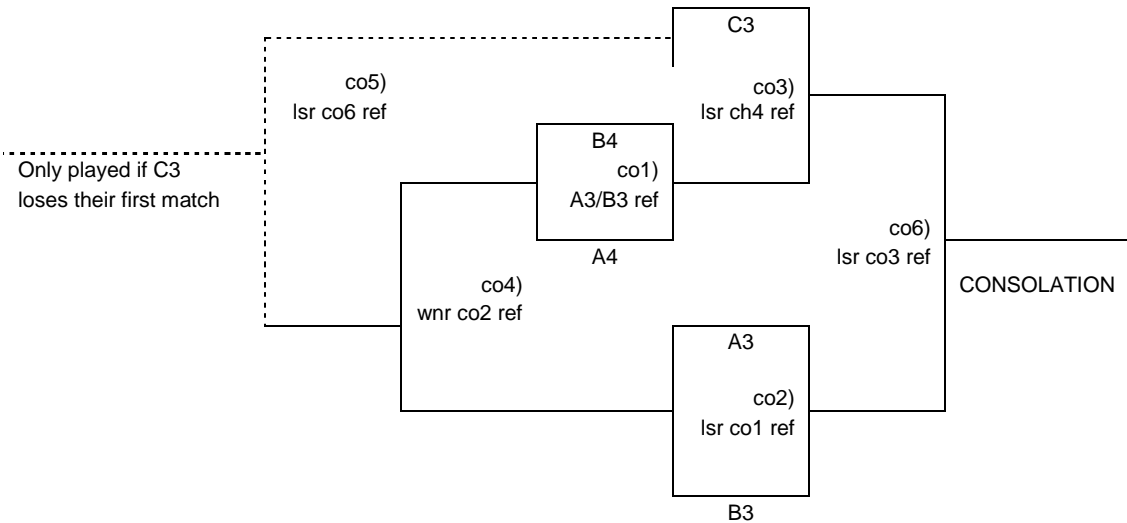

Facility address and tournament instructions on the back page.

Location: The NVA training facility is located at the Abbott Sports Complex.

Address: 7600 N. 70th Street; Lincoln, NE 68517

Tournament Instructions:

1. Each team must provide a team roster from the USA site to the tournament director at the check in table before your first match.
2. All athletes must put their gym bags and other belongings on the shelving provided. Bags left in the bleacher area will be asked to be moved.
3. Outside food, drink and coolers are NOT allowed in the facility. Concessions will be provided by Valentino's. Please leave all other food in your vehicle.
4. Bag chairs are allowed in the facility, in between the bleacher area only. The area in front of the bleachers must remain clear.
5. ABSOLUTELY NO FOOD IN EITHER GYM! NO FOOD AT THE SCORE TABLES!
6. NO GUM is allowed on the courts.

